

Flansch für Vorratsbehälter auf Waage
flange for seed storage bin on top of the weighing scale

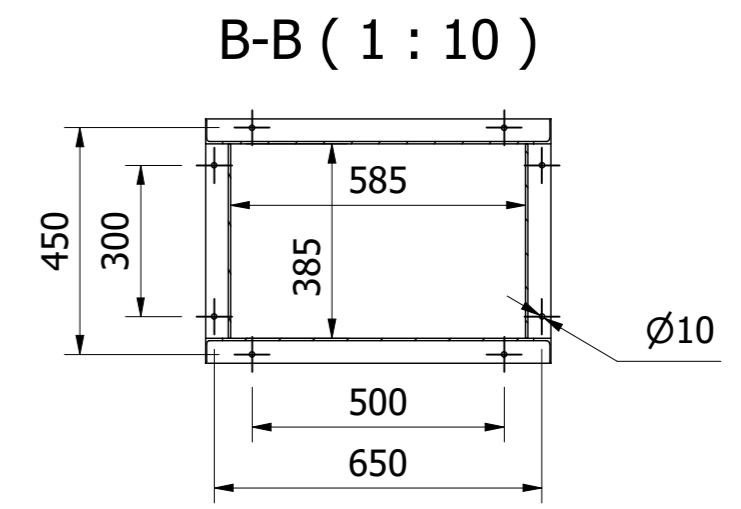

***Bypassklappkasten / by-pass box**
 -Funktion/ *function:*
 ausschleusen zum absacken von ungebeiztem Saatgut.
eject untreated seed to bagging unit.

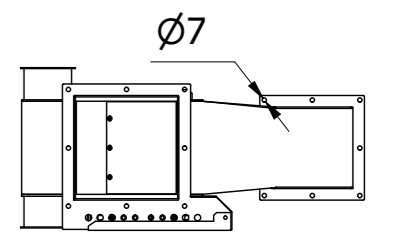
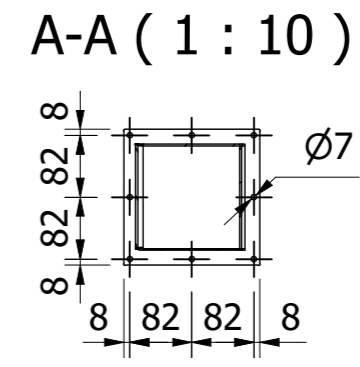
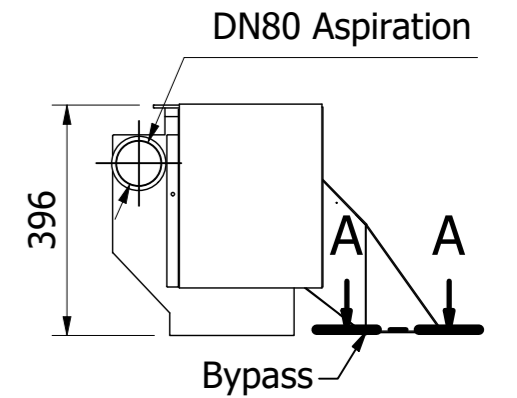

Allgemeine Gewichtsangaben / weight specification
 -Beizer ohne Pulverdosierung/ *Treater without powder dosing unit:* ca. 670kg
 -Pumpenstation/ *liquid dosing unit:* ca. 400kg

Arbeits- & Servicefläche / working- & service-space
 -rund um die Anlage/ *around the machine:* 1000mm

Aspiration
 -Beizer & Pulverdosierung/ *treater / powder dosing unit:* DN80
 -Waage/ *weighing scale:* DN100
 -Aspirationsluftbedarf/ *aspiration air requirement:* ~1350m³/h

Druckluftanschluss / air pressure connection
 -Schlauchtülle/ *hose nozzle* nw 7 2, 6bar
 -Luftverbrauch/ *air consumption:* 350L/h

Elektro- Hauptanschluss / main connection
 - 3ph. / N / PE - 230V / 400V - 50Hz - ca. 15kW
 (1x Pumpenstation 1x Pulver)

Farbgebung / main colour
 -Rotbraun (RAL 8012)

* Sofern im Auftragsumfang enthalten / *if included in the order*

Maßblatt/dimension sheet		
	E-mail: info@wn-niklas.de	
Chargenbeizer universal batch treater	Konstrukteur: Daniel Drews	Projektnummer:
	Datum: 09.11.2021	Maßstab: 1 : 10
	Typen Bezeichnung: WN5-50	

This drawing is our property and may not be copied or shown to a third party without our permission.